



*Robust valve control device giving a confidence in reliable performance and outstanding durability under harsh working environments*

### Features

- ▶ Easy maintenance
- ▶ Precise calibration with simple SPAN and ZERO adjustments
- ▶ Simple conversion to direct acting or reverse acting
- ▶ 1/2 split range available
- ▶ Rugged aluminum housing with corrosion-resistant coating
- ▶ Vibration resistant design
- ▶ Stainless steel gauges standard
- ▶ Restricted pilot valve orifice kit for small actuators included

### Options

- ▶ Position transmitter (4-20mA output signal)
- ▶ 2 x SPDT limit switch
- ▶ 2 x P&F proximity sensor NJ2-V3-N
- ▶ Visual dome indicator
- ▶ High temperature

### Specifications

	PPR	
	Rotary Type (Cam Feedback)	
	Single	Double
Input Signal	0.2 - 1.0 bar (3 - 15 psi) (Note.1, 2)	
Supply Air Pressure	Max. 7.0 bar (100 psi)	
Standard Stroke	60 - 100° (Note.3)	
Pneumatic Connections	Rc 1/4 or NPT 1/4	
Ambient Temperature	-20 - +70 °C	
Pressure Gauge	Stainless steel	
Output Characteristics	Linear	
Linearity	Within ± 1.0 % F.S	Within ± 1.5 % F.S
Sensitivity	Within ± 0.5 % F.S	
Hysteresis	Within 1.0 % F.S	
Repeatability	Within ± 0.5 % F.S	
Air Consumption	5 LPM (Sup. 1.4 bar)	
Flow Capacity	80 LPM (Sup. 1.4 bar)	
Body Material	Aluminium die-cast	
Weight	2.5 kg	



With Dome Indicator

**Note:** 1) 1/2 split range is available for 3-9 psi input signal or 9-15 psi input signal  
 2) Please contact for 6-30 psi input signal  
 3) Operating angle can be adjusted to 0~60° or 0~100°

## How to Order

**PPR** —

Feedback Shaft

Pressure Gauge (SUP. OUT)

Pilot Valve Orifice

Position Feedback

Connection Threads

Dome Indicator

High Temp

Mounting Bracket

Description	Code
<b>Feedback Shaft :</b>	N : NAMUR shaft (direct mounting) A : Fork lever M6 x 40L B : Fork lever other size on request
<b>Pressure Gauge :</b>	1 : 6 bar (90 psi) 2 : 10 bar (150 psi)
<b>Pilot Valve Orifice :</b>	S : Standard (Actuator volume over 180 cm <sup>3</sup> ) M : Small orifice ( $\phi$ 1.0 or $\phi$ 0.7) (Actuator volume 90~180 cm <sup>3</sup> )
<b>Position Feedback :</b>	N : None (standard) O : Position transmitter (4~20mA output signal) L : 2 x SPDT limit switch P : 2 x proximity sensor P&F NJ2-V3-N M : O+L Q : O+P

Description	Code
<b>Connection Threads : (pneumatic)</b>	3 : Rc 1/4 4 : NPT 1/4
<b>Dome Indicator :</b>	N : Flat indicator (standard) D : Dome indicator
<b>High Temperature :</b>	T : 70°C (standard) H : 120°C (without position feedback option) 85°C (with position feedback option)
<b>Mounting Bracket :</b>	N : None
<b>• NAMUR Shaft Type :</b>	R : Multi-size NAMUR bracket for DIN VDI/VDE 3845 (130 x 30 x 50 bracket on request)
<b>• Fork Lever Type :</b>	F : DHCT bracket 80x30 for fork lever type E : Multi-size NAMUR bracket for fork lever type (130 x 30 x 50 bracket on request)

## Dimensions

### A. With Flat Indicator

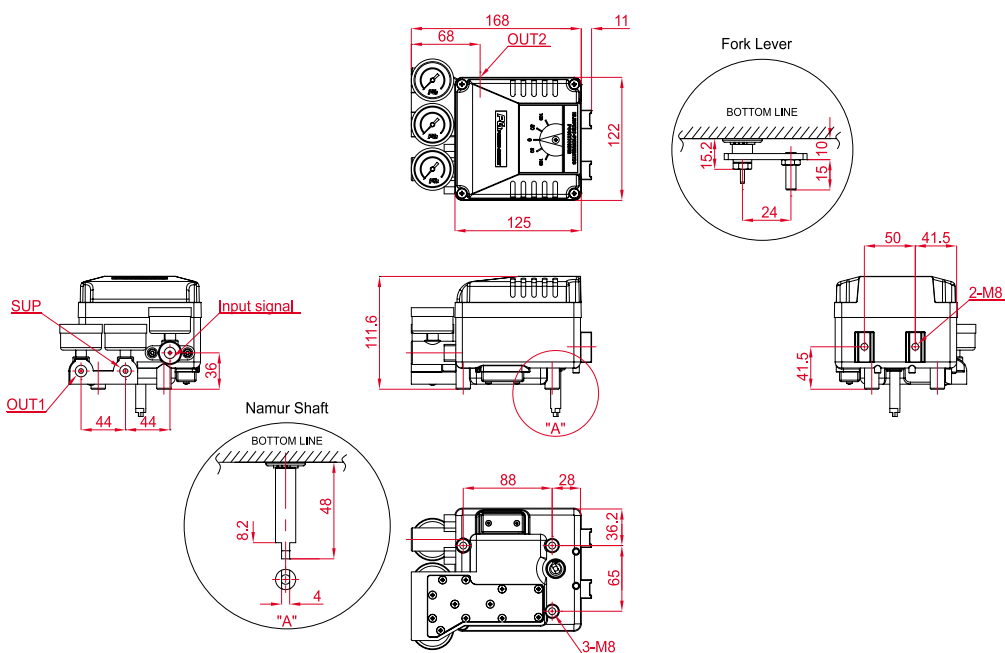

### B. With Dome Indicator

