



Multidial Type Precision Needle Valve (Ideal for restriction of flows by dial control operation)

MODEL 2412M SERIES

This is an enhanced model of the KOFLOC Precision Needle Valve Model 2412 (see page 102), which now incorporates a multidial that allows the user to set desired flow rates by dial operations. This valve makes the most of the rotation-to-flow linearity and repeatability performance of the 2412 needle.

Features

- Since a precision needle valve usually has superior flow characteristics and repeatability, it can be used in place of a needle valve flowmeter.
- Wide variations are available for both the needle valve (Type T, Type L, and so on) and the multidial (Standard Type, Round Type, and so on).

Note: No scale calibration is required for the multidial.

Applications

- Detection of deteriorated filters
- Substitute for a flowmeter
- Detection of fluctuations of flow path resistance

Standard Specifications

Regulating screw rotating speed	Multidial: 10 turns (Overscale possible) Needle valve: Approx. 12 turns
Multidial scale	3-digit setting (000-999)
Multidial type	A: Standard multidial B: Round multidial
Connection end	Rc1/4; Rc1/8 (Optional)
Flow rating	See Table of Rated Flow Ranges for Model 2412 on page 103.

Dimensions

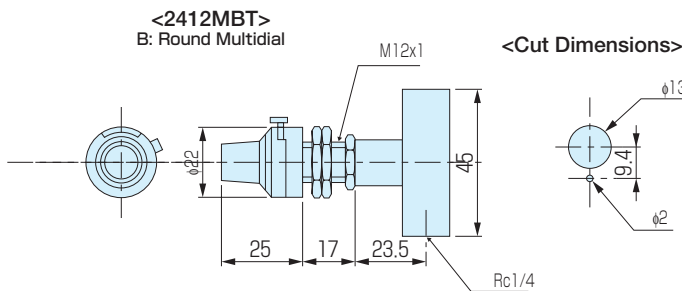
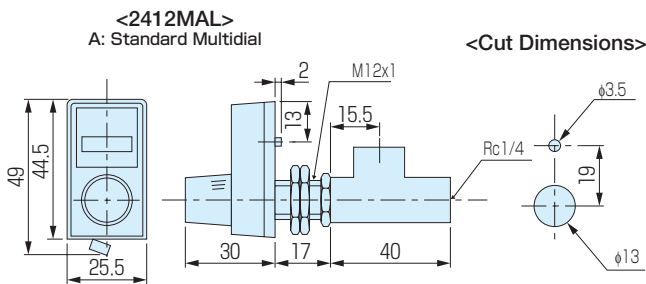

Example of Characteristic Curve

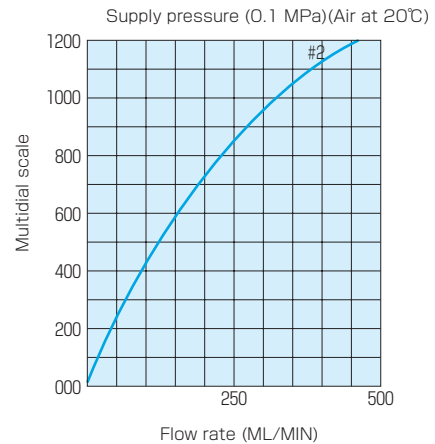

Notes:

- For flow rating, please see Table of Rated Flow Ranges for Model 2412 on page 103.
- You may specify the fluid and pressure flow of your equipment for our selection of the type that most suits your requirements.
- For information on available connection end types other than standard ones.
- The 2412M valve opens when it turns in the direction reverse to the 2412.

Ordering

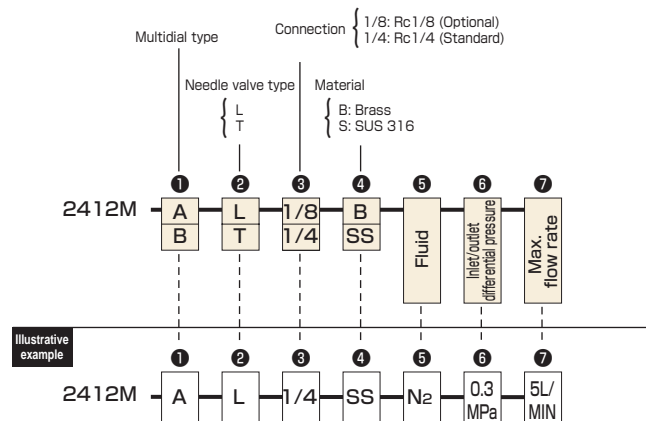

* Refer to "Ordering" and "Illustrative Example" when placing an order or requesting a quotation. Fill in the blanks in the "Order/Quotation Request Card" at the end of the catalog, and send the card by fax.



Table of Rated Flow Ranges (Reference)

Due to operating conditions and instrumental errors, there may be differences in the range of 80% to 130% between the values indicated in this table and those that are actually used by the customer. Please use these values for reference only.

Flow rate when the outlet valve is totally opened to release flows into air

Needle #	Supply pressure (MPa) (Air at 20°C)							Supply pressure (MPa) (Water at 20°C)		
	0.05	0.1	0.2	0.3	0.4	0.5	0.6	0.05	0.1	0.15
BSS1	0.016	0.032	0.058	0.086	0.115	0.14	0.18	—	—	—
BS1	0.074	0.12	0.20	0.28	0.34	0.44	0.52	—	—	—
B1	0.10	0.16	0.24	0.34	0.42	0.53	0.60	—	—	—
B2	0.12	0.19	0.29	0.41	0.50	0.63	0.72	0.0010	0.0017	0.0024
B2A	0.25	0.39	0.60	0.82	1.05	1.30	1.50	0.010	0.015	0.018
B3	0.67	0.98	1.55	2.10	2.65	3.20	3.70	0.019	0.029	0.037
B3B	1.10	1.7	2.5	3.4	4.3	5.1	5.9	0.034	0.05	0.067
B4	4.4	6.3	9.4	12.0	16.0	19.2	22.0	0.15	0.21	0.27
B4A	6.7	9.8	13.9	19.0	24.0	27.9	31.6	0.23	0.32	0.40
B5	7.8	11.3	16.5	20.0	28.0	33.0	38.0	0.26	0.35	0.46
B6	15.3	20.5	32.0	44.0	55.0	68.0	80.0	0.46	0.66	0.79
B6A	21.0	32.0	51.0	70.0	90.0	110	128	0.72	1.0	1.15
B7	40.0	55.0	100	130	170	195	230	1.18	1.7	1.95

(L/MIN)

CV Values

Needle #	Max. CV value
BSS1	0.00008
BS1	0.0003
B1	0.0004
B2	0.0005
B2A	0.00098
B3	0.0025
B3B	0.0043
B4	0.016
B4A	0.025
B5	0.028
B6	0.051
B6A	0.08
B7	0.14

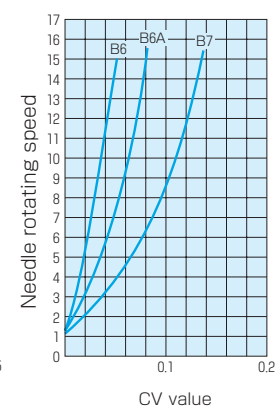
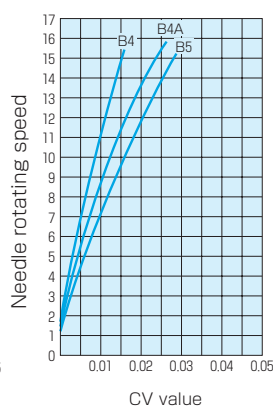
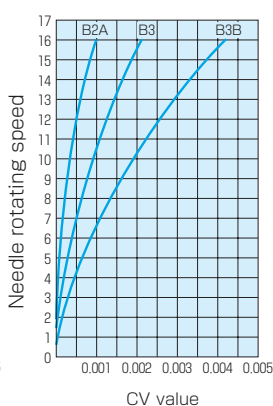
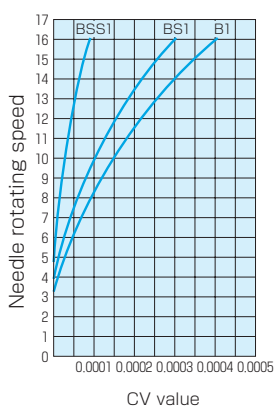

Notes:

- We can suggest you the needle number most suitable for your equipment if the pressure, fluid, flow rate and other operating conditions of your equipment are known. Please use the above table for reference only.

Ordering

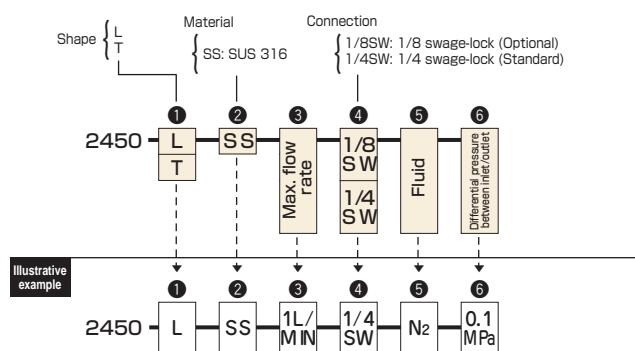

* Refer to "Ordering" and "Illustrative Example" when placing an order or requesting a quotation. Fill in the blanks in the "Order/Quotation Request Card" at the end of the catalog, and send the card by fax.